



REMOTE HANDSET CODING INSTRUCTIONS B&D TRI TRAN REMOTES

TB5



TB6



TO CODE YOUR NEW REMOTE USING THE MOTOR PANEL

If you have access to the motor operating your door, you can use these instructions. However, if the door/gate motor is shared with other tenants at a residential/commercial complex, **do not** use these instructions.

To code in the remote:

1. Ensure your new battery is installed correctly in the new remote
2. Open the cover, if any, on your MOTOR to access the CODE SET BUTTON (see diagrams on reverse)
3. Press and RELEASE the CODE SET button on your MOTOR, the CODE SET LIGHT should go ON
4. Press the remote control button you would like to operate the door, the CODE SET LIGHT should FLASH
5. Press the remote control button AGAIN, the CODE SET LIGHT should go ON for one second then go OFF
6. The programming sequence is complete
7. Press the remote control button to test operation of the door

*Note: IF YOU HAVE A **B&D RECEIVER** follow the above procedures but press **SW1** on the receiver panel, instead of the DOOR CODE button (refer to diagram on reverse)*

To code in the remote to operate 2 or 3 DOORS/GATES:

1. Remove the cover on each door's motor CONTROL PANEL.
2. Repeat the above process using a DIFFERENT button on the remote to operate each door/gate

TO CODE YOUR NEW REMOTE from a WORKING TB-6 REMOTE

If you have a TB6 remote that currently operates a door/gate, you can use these instructions when you are standing in range of the motor without touching the motor (ie. when operating a shared door/gate at an Apartment complex)

1. Ensure your new battery is installed correctly in the new remote
2. Press the button on the working remote to operate the door/gate
3. Press a paperclip/small needle into the hole in the centre of the working TB-6 remote for TWO SECONDS (refer to Diagram 4 on reverse)
4. Within the next 10 seconds: Press the new remote control button you would like to operate the door/gate for TWO SECONDS, release for TWO SECONDS, then press again for TWO SECONDS
5. Wait ten seconds then test: Press the new remote control button to confirm operation of the door/gate

TO DELETE ALL STORED CODES FROM A DOOR

Do not do this if the door is shared with other tenants at a residential/commercial complex.

1. Press and hold down the CODE SET button for APPROX SIX SECONDS – until the LEARN light FLASHES
2. When the LEARN light switches OFF all remotes will no longer operate the door

Thank you for your purchase.

Our Customer Support team are available weekdays 8am-5pm on (07) 5476 9227 if you have any further questions.

DIAGRAM 1 : ON CURRENT STYLE DOOR MOTORS:

THE CODE SET BUTTON IS SHOWN AS "2" IN DIAGRAM BELOW
 THE CODE SET LIGHT IS SHOWN AS "1" IN DIAGRAM BELOW

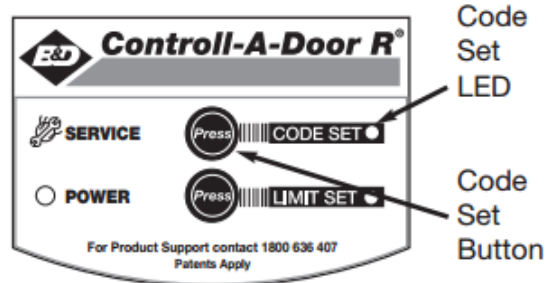
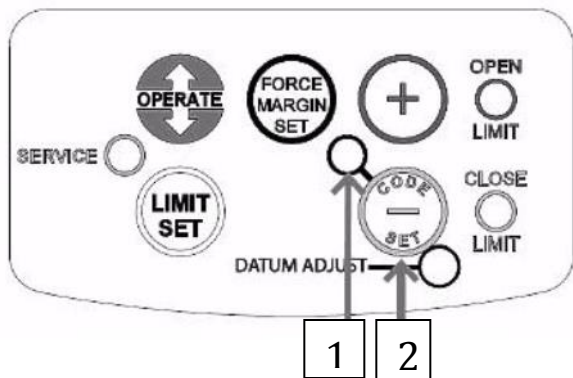

DIAGRAM 2 : ON OLDER STYLE DOOR MOTORS:

THE CODE SET BUTTON IS SHOWN AS "2" IN DIAGRAM BELOW
 THE CODE SET LIGHT IS SHOWN AS "1" IN DIAGRAM BELOW

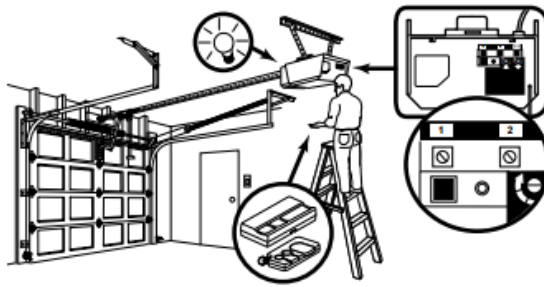
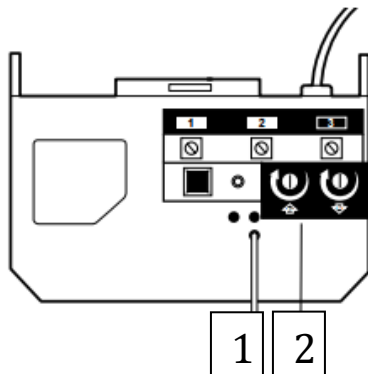

DIAGRAM 3 : ON GATE MOTORS:

Open the cover on the Control Unit by removing the 4 screws. Locate the Receiver Board as shown below:

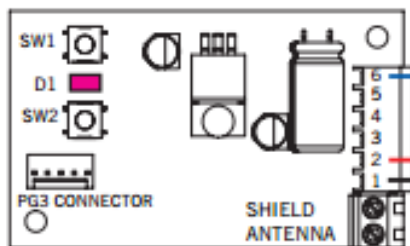
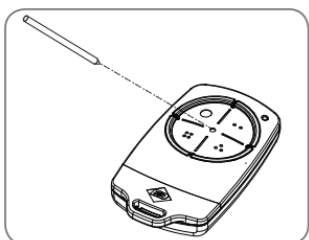

DIAGRAM 4 : WORKING TB-6 REMOTE:



*Thank you for your purchase.
 Our Customer Support team are available weekdays 8am-5pm on (07) 5476 9227 if you have any further questions.*